

*TB 9-6625-2179-35

DEPARTMENT OF THE ARMY TECHNICAL BULLETIN

CALIBRATION PROCEDURE FOR MODULATION METER ME-505 A/U (MARCONI INSTRUMENTS, MODEL 2305)

Headquarters, Department of the Army, Washington, DC
29 February 2008

Distribution Statement A: Approved for public release; distribution is unlimited.

REPORTING OF ERRORS AND RECOMMENDING IMPROVEMENTS

You can improve this manual. If you find any mistakes or if you know of a way to improve these procedures, please let us know. Mail your letter or DA Form 2028 (Recommended Changes to Publications and Blank Forms) directly to: Commander, U.S. Army Aviation and Missile Command, ATTN: AMSAM-MMC-MA-NP, Redstone Arsenal, AL 35898-5000. A reply will be furnished to you. You may also send in your comments electronically to our E-mail address: 2028@redstone.army.mil or by fax 256-842-6546/DSN 788-6546. For the World Wide Web use: <https://amcom2028.redstone.army.mil>. Instructions for sending an electronic 2028 can be found at the back of this manual.

SECTION		Paragraph	Page
	I. IDENTIFICATION AND DESCRIPTION		
	Test instrument identification	1	2
	Forms, records, and reports	2	2
	Calibration description	3	2
	II. EQUIPMENT REQUIREMENTS		
	Equipment required	4	3
	Accessories required	5	3
	III. CALIBRATION PROCESS		
	Preliminary instructions	6	4
	Equipment Setup	7	4
	Internal oscillator.....	8	5
	Frequency accuracy.....	9	5
	AM and FM accuracy	10	6
	Input power and sensitivity.....	11	8
	Filters.....	12	9
	Final procedure	13	10

*This technical bulletin supersedes TB 9-6625-2179-35, dated 11 July 1988, including all changes.

SECTION I IDENTIFICATION AND DESCRIPTION

1. Test Instrument Identification. This bulletin provides instructions for the calibration of Modulation Meter, ME-505 A/U, (Marconi Instruments, Model 2305). TM 11-6625-3146-14 was used as the prime data source in compiling these instructions. The equipment being calibrated will be referred to as the TI (test instrument) throughout this bulletin.

a. Model Variations. None.

b. Time and Technique. The time required for this calibration is approximately 3 hours, using the microwave technique.

2. Forms, Records, and Reports. Forms, records, and reports required for calibration personnel at all levels are prescribed by TB 750-25.

3. Calibration Description. TI parameters and performance specifications which pertain to this calibration are listed in table 1.

Table 1. Calibration Description

Test instrument parameters	Performance specifications
Internal oscillator	Range: 10 MHz Accuracy: 0.5ppm after 5 min warm up
Frequency measurement	Range: 500 kHz to 2.0 GHz Accuracy: ± 1 count (\pm STD oscillator accuracy)
AM measurement	Range: 0 to 95% Accuracy: ¹ $\pm 1\%$ rdg \pm LSD at 1 kHz modulation frequency
FM measurement	Range: 0 to 500 kHz deviation ² Accuracy: ¹ $\pm 0.5\%$ rdg ± 1 LSD at 1 kHz modulation frequency (5 to 500 kHz deviation) $\pm 1\%$ <5 kHz deviation
Input power measurement	Range: +10 to +30 dBm ³ Accuracy: ± 1 dBm
Input sensitivity	Range: - 25 dBm (500 kHz to 500 MHz) - 23 dBm (500 MHz to 1 GHz) - 18 dBm (1 to 1.5 GHz) - 15 dBm (1.5 to 2.0 GHz)
Flat filters	Range: 65 to 250 Hz 30 Hz to 50 kHz 10 Hz to 300 kHz ⁴ Accuracy: ± 0.1 dB
3 dB filters	Range: 50 Hz to 15 kHz 300 Hz to 3.4 kHz Accuracy: ± 0.5 dB

¹Calibrated to $\pm 3\%$.

²Calibrated to 400 kHz deviation.

³Calibrated to + 10 dBm.

⁴Not calibrated below 20 Hz and accuracy is specified only from 10 Hz to 150 kHz.

SECTION II EQUIPMENT REQUIREMENTS

4. Equipment Required. Table 2 identifies the specific equipment to be used in this calibration procedure. This equipment is issued with Secondary Transfer Calibration Standards Set AN/GSM-287 or AN/GSM-705. Alternate items may be used by the calibrating activity. The items selected must be verified to perform satisfactorily prior to use and must bear evidence of current calibration. The equipment must meet or exceed the minimum use specifications listed in table 2. The accuracies listed in table 2 provide a four-to-one ratio between the standard and TI. Where the four-to-one ratio cannot be met, the four-to-one ratio accuracy of the equipment selected is shown in parenthesis.

5. Accessories Required. The accessories required for this calibration are common usage accessories, issued as indicated in paragraph 4 above, and are not listed in the calibration procedure.

Table 2. Minimum Specifications of Equipment Required

Common name	Minimum use specifications	Manufacturer and model (part number)
FREQUENCY COUNTER	Range: 20 Hz to 500 MHz Accuracy: $\pm 1 \times 10^{-8}$	Agilent, Model 5345A (MIS-28754/1 Type 1) w/converter, frequency, plug-in, model 5355A (5355A)
MEASURING RECEIVER	Range: 10 to 95% AM 1 to 400 kHz FM Accuracy: $\pm(1.0)\%$ AM $\pm(1.0)\%$ FM	Agilent, Model 8902A w/sensors, Agilent, Model 11722A (11722A) and 11792A (11792A), and microwave converter, model 11793A (11793A)
POWER METER	Range: 0 to 10 dBm Accuracy: ± 0.25 dBm	Agilent, Model E12-432A (MIS-30525) w/thermistor mount, Hewlett-Packard, Model H75-478A (7915907) or 8478B (8478B)
POWER SPLITTER	Range: 500 kHz to 2.0 GHz	Weinschel, Model 1870A (1870A)
SIGNAL GENERATOR	Range: 1 MHz to 2 GHz Accuracy: ¹	(SG-1207/U)
SYNTHESIZER/LEVEL GENERATOR	Range: 20 Hz to 150 kHz Accuracy: $<5 \times 10^{-10}$ per day	Agilent, Model 3335AOPT 001-K06 (MIS-35938)
VARIABLE ATTENUATOR	Range: 0 to 25 dB Accuracy: Test report	Weinschel, Model AF117A-69-34 (AF117A-69-34)

¹Accuracy is determined by frequency counter or power meter depending upon parameter being calibrated.

SECTION III CALIBRATION PROCESS

6. Preliminary Instructions

a. The instructions outlined in paragraphs 6 and 7 are preparatory to the calibration process. Personnel should become familiar with the entire bulletin before beginning the calibration.

b. Items of equipment used in this procedure are referenced within the text by common name as listed in table 2.

c. Unless otherwise specified, verify the result of each test and, whenever the test requirement is not met, take corrective action before continuing with the calibration. Additional maintenance information is contained in TM 11-6625-3146-14 for this TI.

d. Unless otherwise specified, all controls and control settings refer to the TI.

7. Equipment Setup

WARNING

HIGH VOLTAGE is used or exposed during the performance of this calibration. DEATH ON CONTACT may result if personnel fail to observe safety precautions. REDUCE OUTPUT(S) to minimum after each step within the performance check where applicable.

a. Remove protective cover from TI only when necessary to make adjustments. Replace cover after completing the adjustments.

b. Insure **POWER SUPPLY** switch (rear panel of TI) is set for 105 to 120 V operation.

c. Connect TI to 115 V ac power source.

d. Set **SUPPLY** switch to **ON** and allow at least 5 minutes for warm-up and stabilization.

e. Press **CAL** key. When TI self-check is complete, **FREQUENCY** display will indicate PASS (momentarily) and then all dashes (- - - - -).

NOTE

If TI indicates anything other than all dashes (-), or PASS in e above, repair is required before continuing.

NOTE

In all references in this procedure to TI keys that have more than 1 function, the key is to be pressed to light the indicator of the function called for in the text.

8. Internal Oscillator

a. Performance Check

(1) Connect **STD FREQ IN-OUT** (rear panel of TI) to frequency counter. If frequency counter does not read $10\text{ MHz} \pm 5\text{ Hz}$, adjust **STD FREQ ADJ** (rear panel of TI).

(2) Wait 1 hour; then observe frequency counter. If the indication is not $10\text{ MHz} \pm 5\text{ Hz}$, adjust **STD FREQ ADJ** (rear panel of TI).

b. Adjustments. No further adjustments can be made.

9. Frequency Accuracy

a. Performance Check

(1) Connect equipment as shown in figure 1.

(2) Press TI keys as listed in (a) through (e) below:

- (a) **ENTER.**
- (b) **0.**
- (c) **4.**
- (d) **1.**
- (e) **RCL/STO.**

NOTE

After completing (2) above the TI **FREQUENCY** display will indicate **EXT STD** in lower right corner. If not, repeat (2) above.

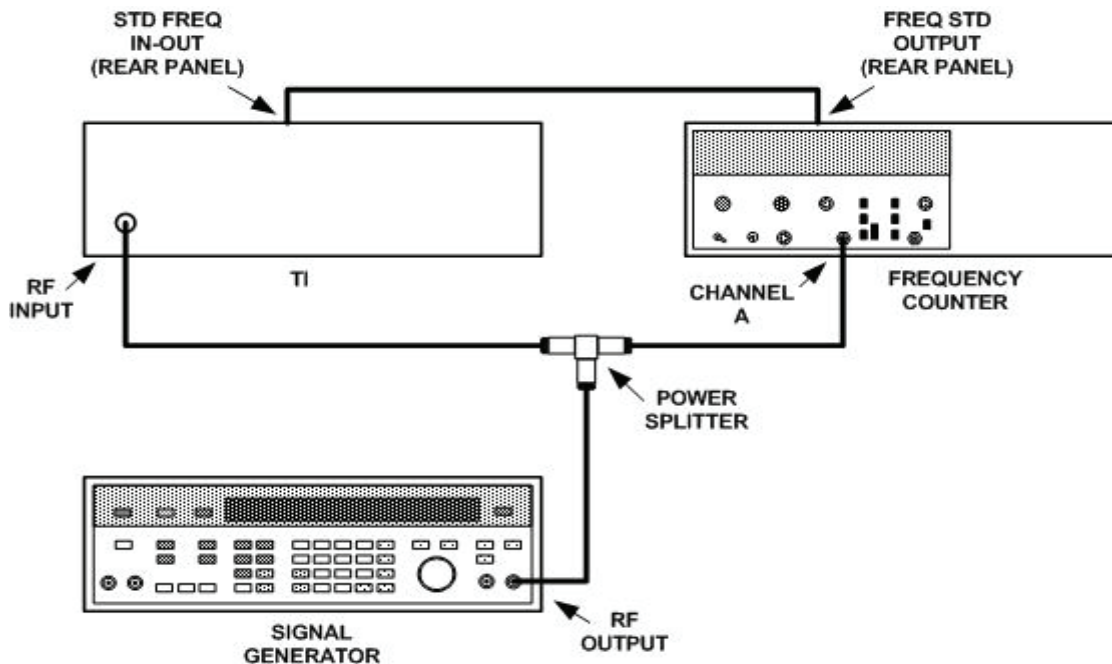

Figure 1. Frequency accuracy - equipment setup.

(3) Adjust signal generator controls for a 500 kHz cw signal with a +10 dBm output level.

NOTE

In (4) and (5) below adjust frequency counter **DISPLAY POSITION** switch as required for equal number digits resolution on frequency counter and TI **FREQUENCY** display.

(4) TI **FREQUENCY** display and frequency counter indication will agree within ± 2 counts.

(5) Repeat (3) and (4) above for signal generator frequencies of 1 MHz, 10 MHz, 100 MHz, 300 MHz, 500 MHz, 1.0 GHz, 1.5 GHz and 2.0 GHz.

NOTE

Signal generator output level may need to be adjusted to maintain a stable indication on TI **FREQUENCY** display.

(6) TI **FREQUENCY** display and microwave measurement system frequency counter indication will agree within ± 2 counts.

(7) Press TI keys as listed in (a) through (e) below:

- (a) **ENTER.**
- (b) **0.**
- (c) **4.**
- (d) **0.**
- (e) **RCL/STO.**

b. Adjustments. No adjustments can be made.

10. AM and FM Accuracy

a. Performance Check

(1) Connect equipment as shown in figure 2.

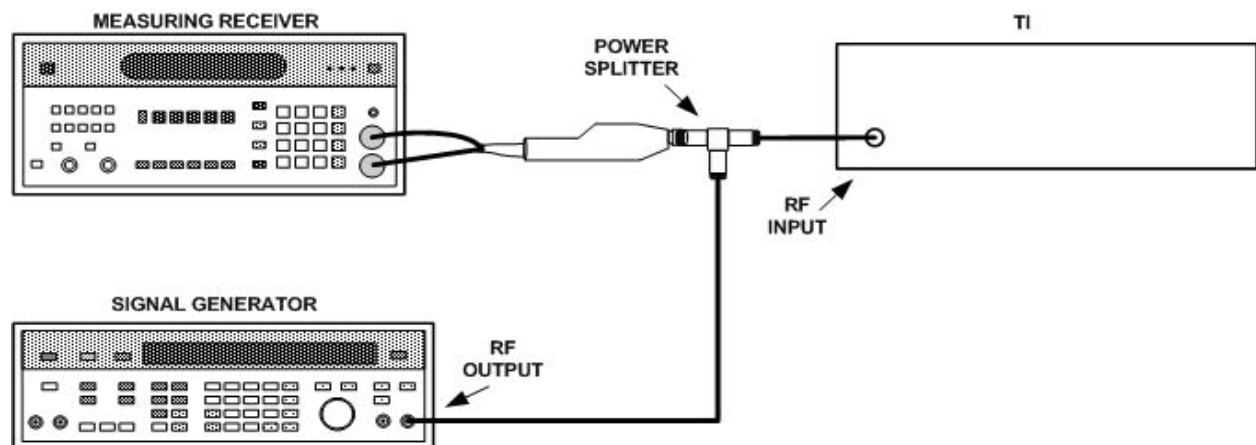

Figure 2. AM and FM accuracy - equipment setup.

- (2) Set signal generator controls **AM** to **INT** and then a 500 MHz output with modulation frequency set to 1 kHz.
- (3) Press TI keys as indicated in (a) through (c) below:
 - (a) **AM**.
 - (b) **ABS**.
 - (c) **P+**.
- (4) Set measuring receiver to measure **AM** modulation with **PEAK + DETECTOR**.
- (5) Adjust signal generator controls for a +10 dBm output level and adjust AM controls for a TI **MODULATION** display indication of 95%.
- (6) Enter TI **MODULATION** display indication on keyboard of measuring receiver and press **RATIO %**. Measuring receiver display will indicate between 97 and 103%.
- (7) Repeat technique of (5) and (6) above for TI **MODULATION** display indications of **90, 80, 70, 60, 50, 40, 30, 20, and 10%**.
- (8) Repeat (5) through (7) above for signal generator modulation frequency settings of 50 Hz and 15 kHz.
- (9) Set signal generator controls for a 2 GHz output with a modulation frequency of 50 kHz.
- (10) Repeat (5) through (7) above.
- (11) Set measuring receiver for **PEAK - DETECTOR** operation and press TI **P -** key. Repeat (5) and (6) above.
- (12) Set signal generator **FM** to **INT**.
- (13) Press TI **FM** and **P+** keys.
- (14) Set measuring receiver to measure FM modulation with **PEAK + DETECTOR**.
- (15) Adjust signal generator controls for a 500 MHz signal at +10 dBm output with modulation frequency set to 1 kHz. Adjust FM deviation for a TI **MODULATION** display indication of 400 kHz.
- (16) Enter TI **MODULATION** display indication on keyboard of measuring receiver and press **RATIO %**. Measuring receiver display will indicate between 97 and 103%.
- (17) Repeat technique of (15) and (16) above for TI **MODULATION** display indications of **300, 200, 100, 50, 10, 4, and 1 kHz**.
- (18) Set signal generator modulation frequency to 10 kHz and deviation to 10 kHz. Adjust FM control for a TI **MODULATION** display indication of 10 kHz.
- (19) Repeat (16) above.
- (20) Set signal generator deviation to 20 kHz and adjust FM control for a TI **MODULATION** display indication of 20 kHz.
- (21) Repeat (16) above.
- (22) Set signal generator modulation frequency to 100 kHz and deviation to 100 kHz. Adjust FM control for a TI **MODULATION** display indication of 100 kHz.

(23) Repeat (16) above.

(24) Set measuring receiver for **PEAK - DETECTOR** operation and press TI **P**- key.

(25) Repeat (16) above.

b. **Adjustments.** No adjustments can be made.

11. Input Power and Sensitivity

a. Performance Check

(1) Connect equipment as shown in figure 3.

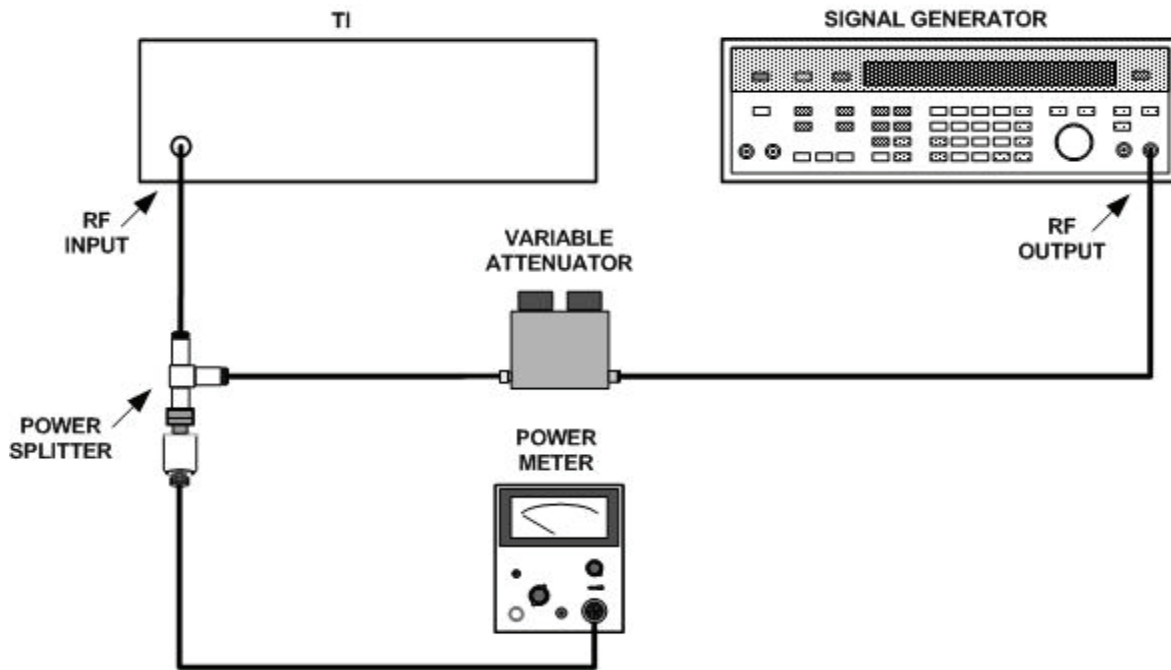

Figure 3. Input power and sensitivity - - equipment setup.

(2) Set variable attenuator to 0 dB.

(3) Set signal generator controls for a 490 MHz cw output. Adjust output level controls for a +10 dBm indication on power meter.

(4) Press TI **POWER** key. TI **MODULATION** display will indicate between 9 and 11 dBm.

(5) Press TI **POWER** key to turn power measurement off.

(6) Adjust signal generator output level controls for a 0 dBm power meter indication.

(7) Increase variable attenuator until TI **FREQUENCY** display indicates all dashes (- - -) or an error code (i.e., 54).

NOTE

All variable attenuator indications in (8) through (18) below must be computed from the test report for the variable attenuator.

- (8) Variable attenuator will indicate 25 dB or greater.
- (9) Repeat (2) above.
- (10) Set signal generator output frequency to 990 MHz. Adjust output level control for a 0 dBm indication on power meter.
- (11) Repeat (7) above.
- (12) Variable attenuator will indicate 23 dB or greater.
- (13) Repeat (2) above.
- (14) Repeat (10) and (11) above for a signal generator output of 1.49 GHz.
- (15) Variable attenuator will indicate 18 dB or greater.
- (16) Repeat (2) above.
- (17) Set signal generator output frequency to 1.99 GHz and repeat (10) and (11) above.
- (18) Variable attenuator will indicate 15 dB or greater.

b. Adjustments. No adjustments can be made.

12. Filters**a. Performance Check**

- (1) Repeat paragraph 7 e.
- (2) Connect RF output of signal generator to **TI RF INPUT**.
- (3) Connect synthesizer/level generator output to signal generator **FM** input and frequency counter **CHANNEL A INPUT**.
- (4) Set signal generator controls for a 500 MHz output with **MODULATION SOURCE** pushbutton set to **EXT AC**.
- (5) Adjust synthesizer/level generator to 1 kHz as indicated on frequency counter with an output level of 1 V. Establish a 0 reference on synthesizer/level generator.
- (6) Adjust signal generator output level controls for a +10 dBm output and set deviation to 160 kHz.
- (7) Adjust signal generator FM control for a 100 kHz deviation.
- (8) Press **TI 10-300K FILTER Hz** and **FM** keys.
- (9) Press **ABS** key. After **TI MODULATION** display indication stabilizes press **REL** key.
- (10) Vary synthesizer/level generator frequency from 20 Hz to 150 kHz, as indicated on frequency counter, while maintaining reference established in (5) above. The **TI MODULATION** display will indicate **0.00 ±0.1 dB**.
- (11) Repeat (5) above.

- (12) Press TI **30-50K FILTER Hz** key and repeat (9) above.
- (13) Repeat (10) above for synthesizer/level generator frequency of 30 Hz to 50 kHz.
- (14) Repeat technique of (5) above for synthesizer/level generator frequency of 100 Hz.
- (15) Press TI **65-250 FILTER Hz** key and repeat (9) above.
- (16) Repeat (10) above for synthesizer/level generator frequency of 65 to 250 Hz.
- (17) Repeat (5) above.
- (18) Press TI **50-15 kHz FILTER Hz** key and repeat (9) above.
- (19) Set synthesizer/level generator frequency to 50 Hz as indicated on frequency counter, while maintaining reference established in (5) above. TI **MODULATION** display will indicate **-3.0 ±0.5 dB**.
- (20) Repeat (19) above for synthesizer/level generator frequency of 15 kHz.
- (21) Repeat (5) above.
- (22) Press TI **300-3.4 kHz FILTER Hz** key and repeat (9) above.
- (23) Repeat (19) above for synthesizer/level generator frequencies of 300 Hz and 3.4 kHz.

b. Adjustments. No adjustments can be made.

13. Final Procedure

- a.** Deenergize and disconnect all equipment.
- b.** Annotate and affix DA label/form in accordance with TB 750-25.

By Order of the Secretary of the Army:

Official:

JOYCE E. MORROW
*Administrative Assistant to the
Secretary of the Army*

GEORGE W. CASEY, JR.
*General, United States Army
Chief of Staff*

0802823

Distribution:

To be distributed in accordance with the initial distribution number (IDN) 342265, requirements for calibration procedure TB 9-6625-2179-24.

Instructions for Submitting an Electronic 2028

The following format must be used if submitting an electronic 2028. The subject line must be exactly the same and all fields must be included; however, only the following fields are mandatory: 1, 3, 4, 5, 6, 7, 8, 9, 10, 13, 15, 16, 17, and 27.

From: "Whomever" whomever@redstone.army.mil

To: <2028@redstone.army.mil

Subject: DA Form 2028

1. **From:** Joe Smith
2. **Unit:** home
3. **Address:** 4300 Park
4. **City:** Hometown
5. **St:** MO
6. **Zip:** 77777
7. **Date Sent:** 19-OCT -93
8. **Pub no:** 55-2840-229-23
9. **Pub Title:** TM
10. **Publication Date:** 04-JUL-85
11. **Change Number:** 7
12. **Submitter Rank:** MSG
13. **Submitter FName:** Joe
14. **Submitter MName:** T
15. **Submitter LName:** Smith
16. **Submitter Phone:** 123-123-1234
17. **Problem:** 1
18. **Page:** 2
19. **Paragraph:** 3
20. **Line:** 4
21. **NSN:** 5
22. **Reference:** 6
23. **Figure:** 7
24. **Table:** 8
25. **Item:** 9
26. **Total:** 123
27. **Text**

This is the text for the problem below line 27.

